



legalEyesHHPi

Multi mode legaliser
25/10/06 VI.00

user manual

Table of Contents

1 System Overview	4
1.1 Legaliser Processing.....	4
1.2 Proc Amp	4
1.3 Legaliser	5
1.3.1 Composite Mode.....	5
1.3.2 RGB Mode	5
1.3.3 YUV Mode	6
1.3.4 Clip & Knee	6
1.4 Monitoring Output Generation.....	8
1.4.1 Logging	8
2 Installation	9
2.1 Connections to a legalEyesSHPi	9
2.2 Associated Equipment for the legalEyesSHPi.....	9
3 Control Panel	10
4 Operation	12
4.1 Manual control of the legalEyesHHPi.....	12
4.2 Automation Control of the legalEyesSHPi.....	12
4.3 Operational Menus for the legalEyesSHPi.....	12
5 PC Logging Application	36
5.1.1 Installation.....	36
5.1.2 Setting Up for Logging	36
5.1.3 Understanding the Application	36

Table of Figures

Figure 1 - Basic Legaliser Structure	4
Figure 2 - Composite Legaliser Structure.....	5
Figure 3 - RGB Legaliser Structure	6
Figure 4 - YUV Legaliser Structure	6
Figure 5 - Illegal Source	7
Figure 6 - Hard Clipped Output	7
Figure 7 - Soft Clipped Output.....	8
Figure 10 - Typical Connections.....	9
Figure 11 - evolutionDT Control Panel	11
Figure 12 - Logging Application GUI	37

I System Overview

The legalEyesHHPI is a full-featured multi-mode legaliser system using the evolutionDT platform. The main features of the legalEyesHHPI series of legalisers are as follows:

- Provides Legalisation of the HD SDI Input signal with full 10 bit processing throughout.
- Composite, YUV and RGB colour spaces
- Two Independent HD SDI outputs for "Legalise" and user controllable "Legal/Indicate".
- Adjustable Clipping Levels.
- Adjustable soft clipping knee levels. (RGB and YUV).
- Highly effective overshoot and undershoot suppression on the luminance signal.
- Integral luma and chroma gain, black level adjustment & hue rotation.
- EBU 2003 standard legalisation settings.
- 7.5 IRE or 0 IRE Pedestal.
- 6 User Memories.
- Log output with Timecode and PC viewer programme.

I.1 Legaliser Processing

A Block diagram of the legaliser is shown in Figure 1. Each section is discussed below.

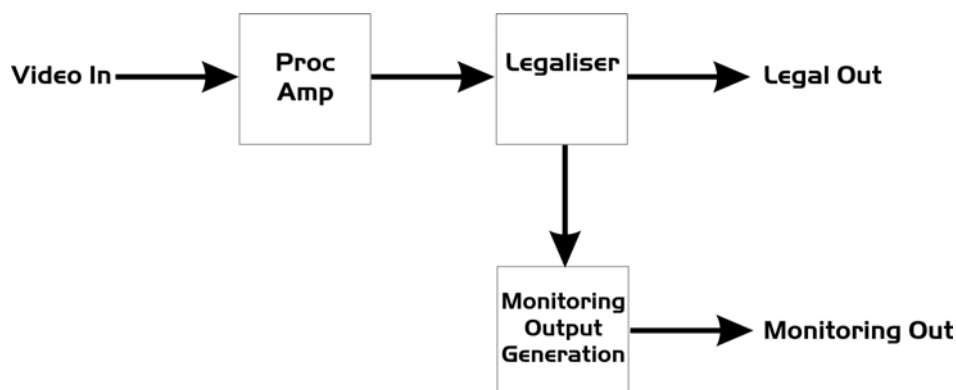

Figure 1 - Basic Legaliser Structure

I.2 Proc Amp

This enables the luma gain to be adjusted from 0 to 200%, Similarly the chroma also is adjustable from 0 to 200%. Full 10 bit by 10 bit Multipliers are used with a rounded 10 bit product. Black level adjustment is also applied at this point as is

hue adjustment which allows for $\pm 180^\circ$ of hue rotation. These controls are accessed via the “Picture” menu.

1.3 Legaliser

The legaliser operates in one of three modes; RGB, YUV or Composite. The mode is selected via the top level mode menu. Each mode is discussed below. In all modes the legaliser is transparent to pixels within the legal range.

1.3.1 Composite Mode

The basic form of the composite legaliser is shown in Figure 2. In composite mode the legaliser restricts the Y, U & V components such that when the signal is converted to a composite waveform the Y component stays within the range allowed by the Y High Clip and Y Low Clip and the total composite waveform stays within the range defined by Comp High Clip and Comp Low Clip.

The legaliser works by selectively reducing the saturation of pixels which would otherwise result in over modulation of the composite waveform. Composite mode preserves the hue of each pixel but not the saturation.

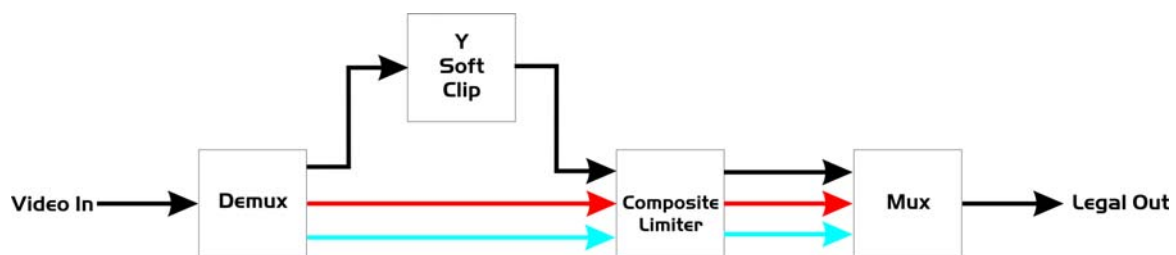

Figure 2 - Composite Legaliser Structure

1.3.2 RGB Mode

The basic form of the RGB legaliser is shown in Figure 3. In RGB mode the legaliser first converts the video from the YUV colour space to the RGB colour space. The RGB data is then soft clipped according to the settings for RGB High Clip & Knee and RGB Low Clip & Knee. Finally the clipped RGB data is converted back to the YUV colour space. The RGB legal colour space is a subset of the composite legal colour space so an RGB legal signal is also composite legal but the reverse is not true.

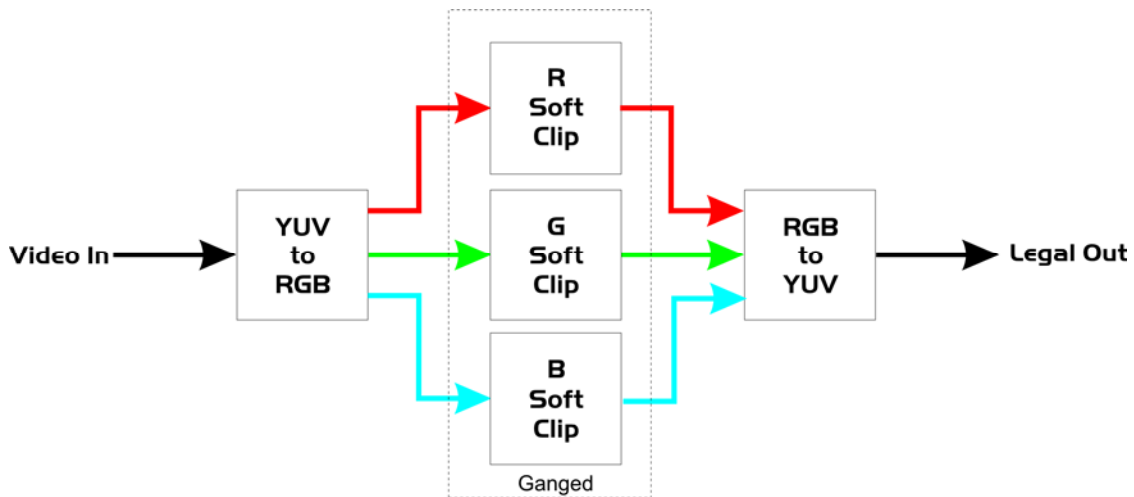

Figure 3 - RGB Legaliser Structure

1.3.3 YUV Mode

The basic form of the YUV legaliser is shown in Figure 4. In YUV mode the legaliser provides direct clipping of the raw YUV data using separate clip and knee parameters for the Y and colour difference components.

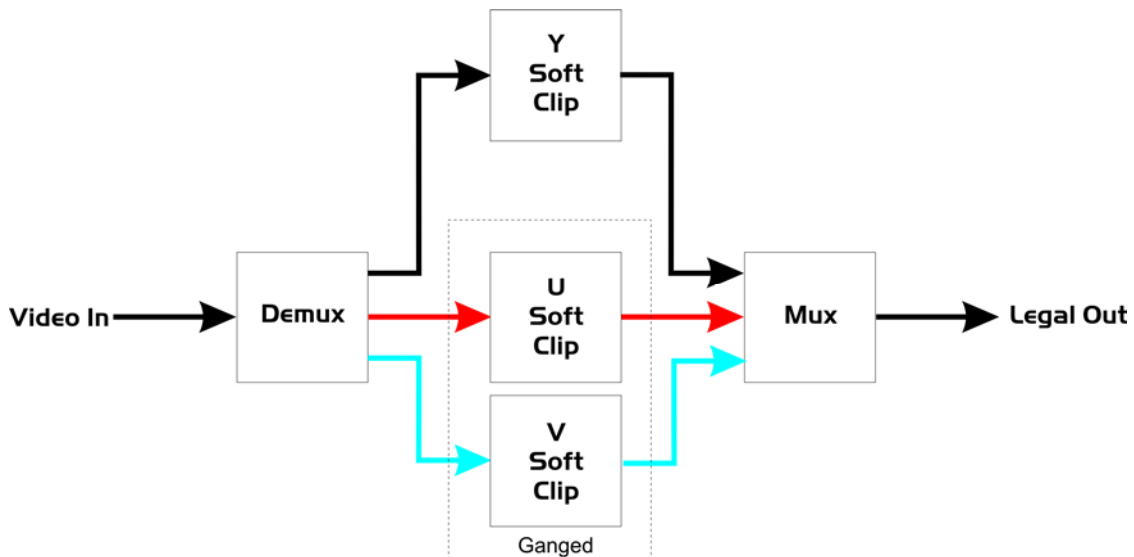

Figure 4 - YUV Legaliser Structure

1.3.4 Clip & Knee

Many of the legaliser functions present Clip and Knee parameters to the user. The Clip parameters specify the maximum and minimum values the system legaliser will allow to pass. Figure 5 shows an illegal input to the clipper with detail in the illegal highlight and lowlight areas of the signal. When the knee values are set to the same value as their respective Clips the legaliser operates as a hard-clipper as shown in Figure 6. The signal is now legal but the detail in the highlights and lowlights has been lost. Figure 7 shows the same input signal legalised with a 10% difference between the Clips and their respective Knees. The highlight/lowlight detail has been compressed into the legal region at the expense of some of the dynamic range of the originally legal part of the waveform.

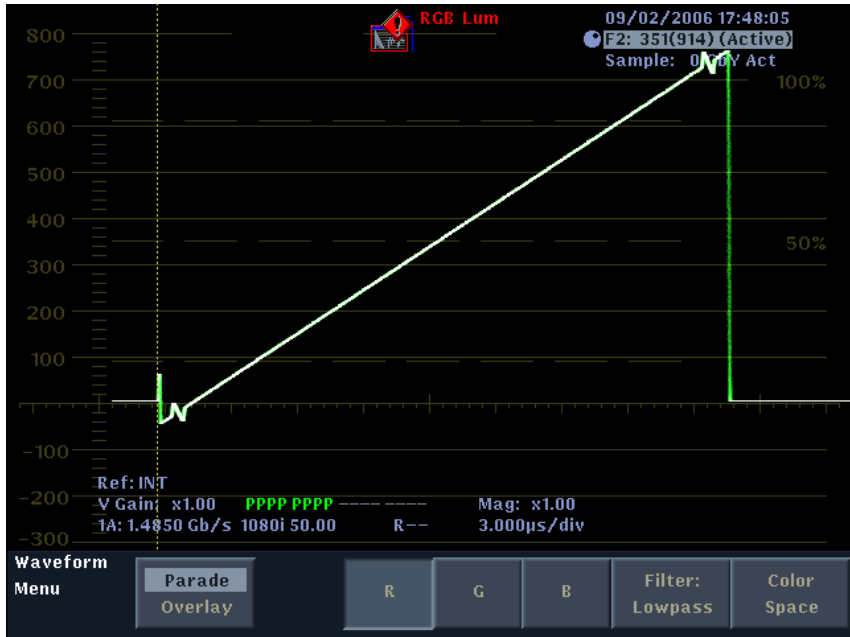

Figure 5 - Illegal Source

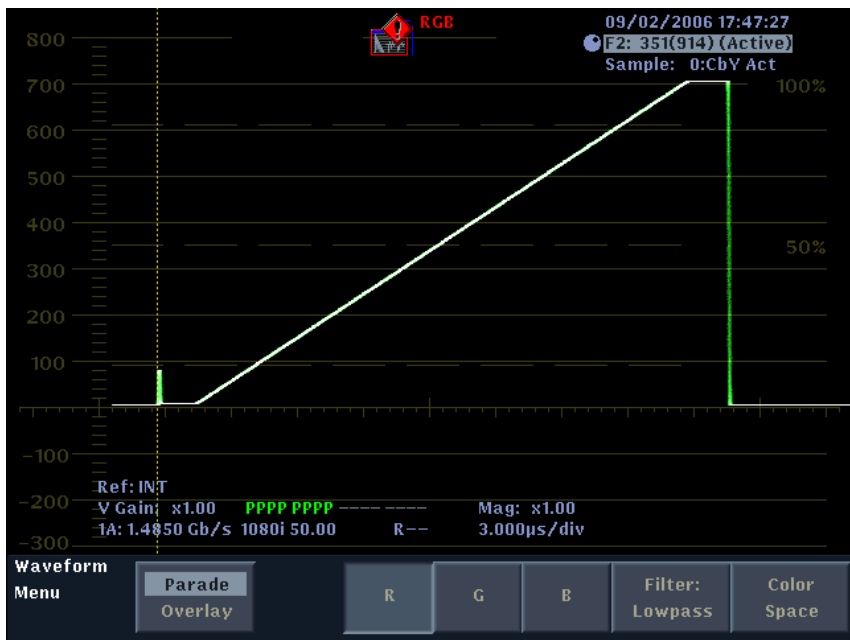

Figure 6 - Hard Clipped Output



Figure 7 - Soft Clipped Output

I.4 Monitoring Output Generation

The second output of the legaliser can be configured either as a second legal output or to display which areas of the picture are being processed by the legaliser. The “MonOp” menu provides control of this feature and allows the user to select which colour is used to represent the processed picture area.

When used as an indicate output the selected colour is keyed over the legal output with the opacity of the colour indicating how illegal the area is. Because signals are typically only slightly illegal the gain on the keyer can be controlled to deliver the desired mix. The gain is controlled by the “Gamut Gain” menu and setting this menu to its maximum value will give the same output as a traditional indicate output.

I.4.1 Logging

In addition to the visual monitoring output the legalEyesHHPi provides a timecode stamped log output via the RS-232 connector which can be connected to a PC running the optional logging application (see section 5 for further details).

2 Installation

2.1 Connections to a legalEyesSHPi

Figure 8 shows the typical connections to the legalEyesSHPi.

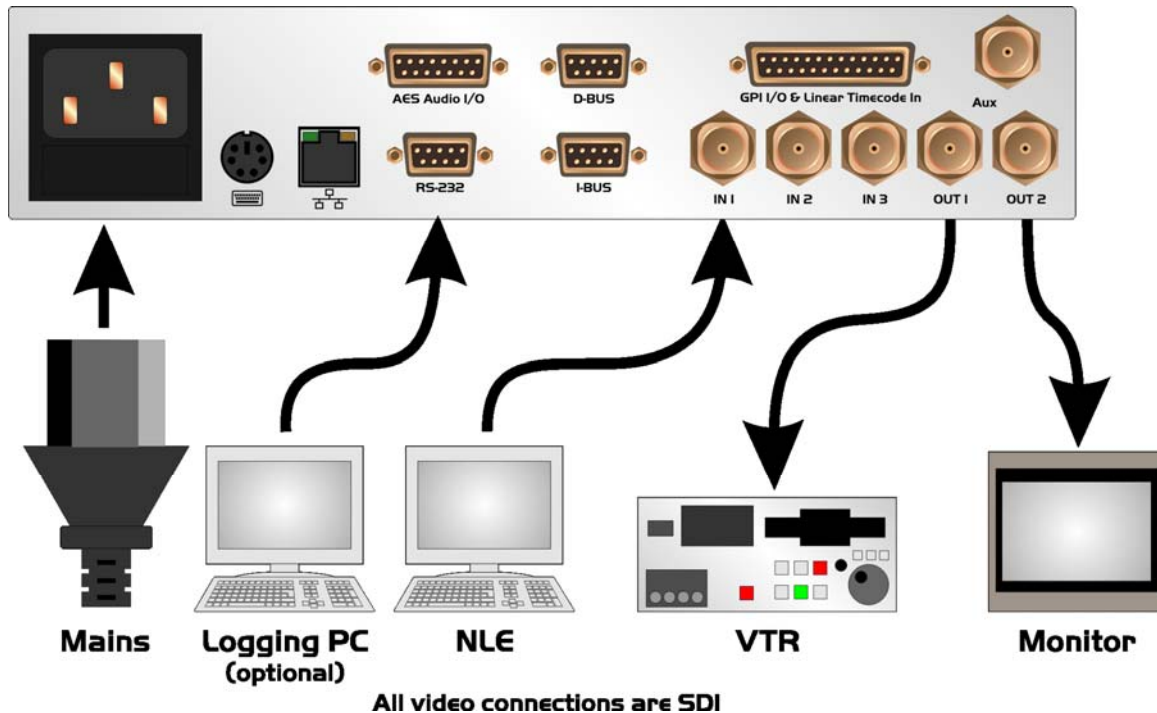

Figure 8 - Typical Connections

IN1 is the HD SDI input. OUT1 is the main HD SDI legalised output. OUT2 is the HD SDI monitoring output which can be switched to show either the legalised output or the indicate display.

2.2 Associated Equipment for the legalEyesSHPi

The legalEyesHHPi in the evolutionDT platform is fully self-contained. The evolutionDT can optionally be rack mounted in with 1 or 2 units in a 19" rack using the optional FF-6 rack mounting. This is a factory-installed option and should be ordered with the product. Rack mounted units should be supported with suitable chassis supports.

3 Control Panel

Figure 9 shows the control panel of the evolutionDT platform.

1 - Power/Status LED

Green – Normal operation

Green Flashing - Version Information Display

Orange – Product is initialising

Flashing Red – Product is in Field Reprogramming Mode

2 - Menu Display/Button (1 of 4)

Displays Menu Information. The colour of the menu button indicates the function.

Green – adjustment menu. Pressing the menu or using the associated digipot(6) will adjust the menu value.

Yellow – information menu, no adjustment possible.

Blue – navigation menu. Pressing the button will take you up or down the menu hierarchy.

Red – multiple variable menu. Pressing the button will “open” the menu assigning one digipot(6) to each variable. The active LED(5) will light above the digipots associated with each variable.

3 - Next Menu Button

Within a layer of the menu hierarchy there may be more than four menus and where this is the case the “next” button will illuminate to show that further menus are available. Pressing the “next” button moves you to the next set of menus.

4 – Previous Menu Button

Within a layer of the menu hierarchy there may be more than four menus and where this is the case the “prev” button will illuminate to show that previous menus are available. Pressing the “prev” button moves you to the previous set of menus.

5 – Digipot Active LED (1 of 4)

Illuminates to indicate that the digipot below is active for adjustment of the associated menu variable.

6 – Digipot (1 of 4)

Allows for rapid adjustment of the associated menu variable.

7 – Next Device Button

It is possible to control more than one device from a single evolutionDT control panel. Where more than one device is assigned to the panel the “next dev” will move control to the next device in the device list.

In setup mode this button will pick up a free device and assign it to this panels device list. The button will flash to indicate that a free device is selected.

8 – Previous Device Button

Where more than one device is assigned to the panel the “prev dev” will move control to the previous device in the device list.

In setup mode this button will remove a device owned by this panel from this panels device list. The button will flash to indicate an owned device is selected.

9 – Info Button

This button displays all hardware, software and firmware version information for the currently selected product and this panel.

In setup mode where a free evolutionDT device is selected this button will flash indicating that the network address (box & slot) can be changed. Pressing this button will take you to the adjustment menus.

10 – Setup Button

Press and hold this button for four seconds to enter setup mode.

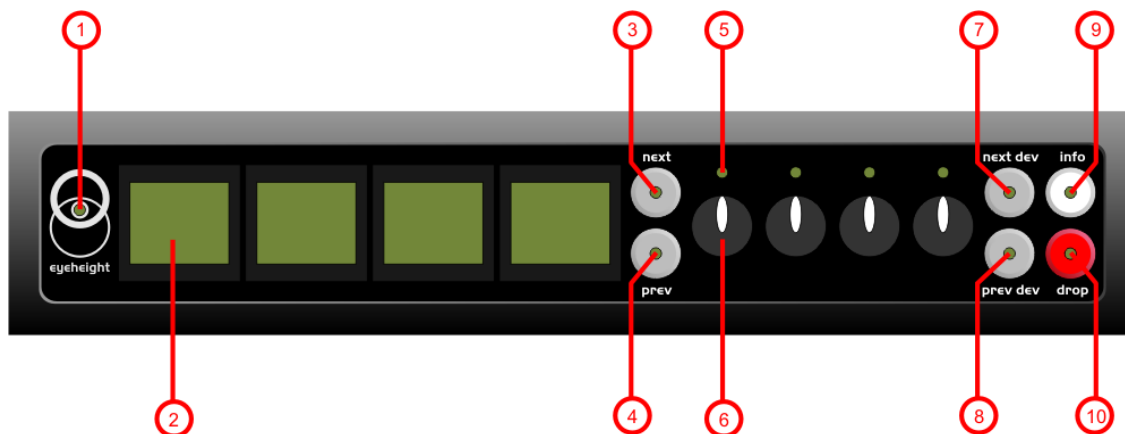

Figure 9 - evolutionDT Control Panel

4 Operation

4.1 Manual control of the legalEyesHHPi

The legalEyesHHPi is controlled using a set of MENUS. Each of these menus contains up to 3 parameters that are adjusted using the rotary digipots. The Menus define all of the adjustable operational parameters in the legalEyesSHPi. See chapter 3 Control Panel Operation for details of the control panel operation. See section 3 of this chapter for the full list of menus.

4.2 Automation Control of the legalEyesSHPi

Automation of the evolutionDT products is achieved either via the RS232 port (currently not implemented) or via the I-Bus Port using an optional DG-9 (RS232 to I-Bus dongle). Automation control of the legalEyesHHPi is performed using the geNETics Automation Protocol.

Genetics protocol is described in detail in the “geNETics User Guide” section titled “Automation Protocol on the geNETics Platform”. The menu list in section 3 of this chapter contains the data information for the protocol.

Please refer to the “User guide for the DG-9 eyeheight dongle and set-up software.

4.3 Operational Menus for the legalEyesSHPi

Menu 00-03: Top Level Menus

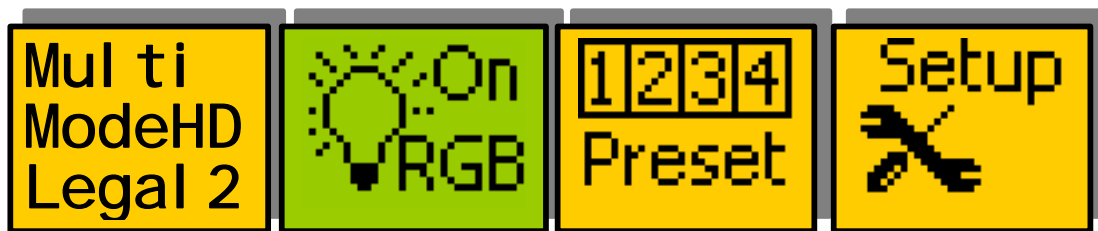

Menu Num.	Heading	Automation	Function
00	Product Name	none	Press this to display the product software version.

01	MODE	OFF RGB YUV COMP [0→3]	Selects the legaliser modes
02	PRESET	none	Go to the main Preset menus (4-7)
03	SETUP	none	Go to the main Setup menus (8-11)

Menu 04-07: Preset Menus



Menu Num.	Heading	Automation	Function
04	STND PRESET	none	Go to the User Preset menus (12-15)
05	USER PRESET	none	Go to the Standard Preset menus (20-23)
06		none	
07	BACK	none	Back to the main operational menus (0-3)

Menu 08-11: Setup Menus

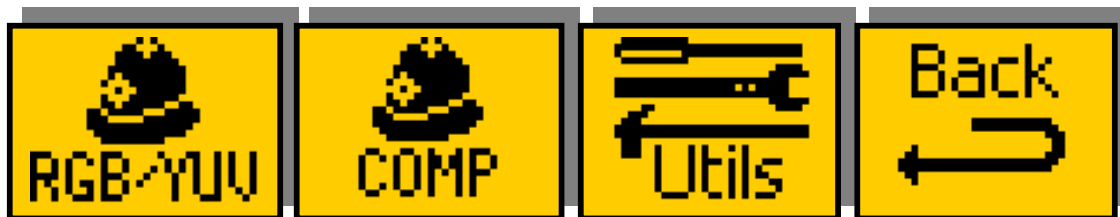

Menu Num.	Heading	Automation	Function
08	RGB/YUV	none	Got to the RGB/YUV main menus (36-39)

09	COMP	none	Go to the main COMP menus (80-83)
10	UTILS	none	Go To the main Utility menus (108-115)
11	BACK	none	Back to the main Operation menus (0-3)

Menus 12-15: Presets

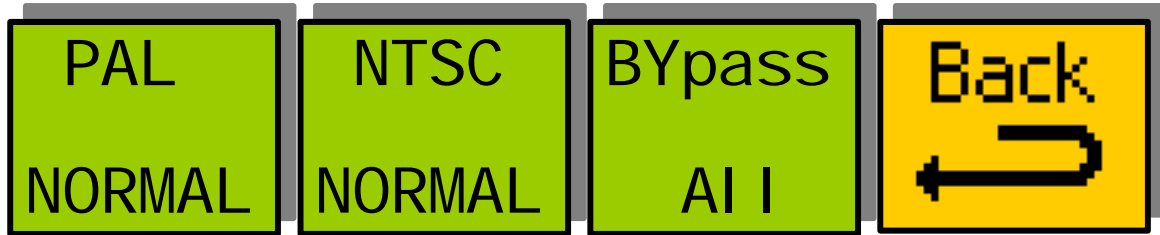

Menu Num.	Heading	Automation	Function
12	PAL NORMAL Preset Setting	1=Recall (Variable 1)	Pressing this will Set The system to Composite Clipping: Hi Luma Clip = +700mv Hi Chroma Clip = +931mv Lo Luma Clip = +0mv Lo Chroma Clip = -230 Hi Luma Knee = +700mv Hi Chroma Knee = +931mv Lo Luma Knee = +0mv Lo Chroma Knee = -230
13	NTSC NORMAL Preset Setting	1=Recall (Variable 1)	Pressing this will Set The system to Composite Clipping: Hi Luma Clip = +702mv Hi Chroma Clip = +843mv Lo Luma Clip = +38mv Lo Chroma Clip = -185 Hi Luma Knee = +702mv Hi Chroma Knee = +843mv Lo Luma Knee = +38mv Lo Chroma Knee = -185
14	Bypass All	1=Recall (Variable 1)	Pressing this will Set The Legaliser to OFF
15	BACK	none	Go back to the main Preset menus (4-7)

Menus 16-19: Presets

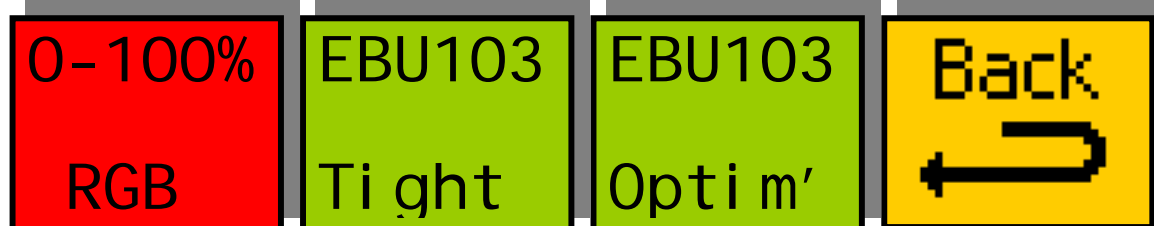

Menu	Heading	Automation	Function
16	0-100% RGB Preset Setting	1=Recall	Pressing this will Set The system to RGB Clipping: Hi RGB Clip = 100% Lo RGB Clip = 0.0% Hi RGB Knee = 100% Lo RGB Knee = 0.0%
17	EBU 103 Tight Setting	1=Recall (Variable 1)	Pressing this will Set The system to RGB Clipping: Hi RGB Clip = 103% Lo RGB Clip = -1.0% Hi RGB Knee = 103% Lo RGB Knee = -1.0%
18	EBU 103 Optimum Setting	1=Recall (Variable 1)	Pressing this will Set The system to RGB Clipping: Hi RGB Clip = 101% Lo RGB Clip = 0.0% Hi RGB Knee = 101% Lo RGB Knee = 0.0%
19	BACK	none	Go back to the main Preset menus (4-7)

Menus 20-23: Memory Controls

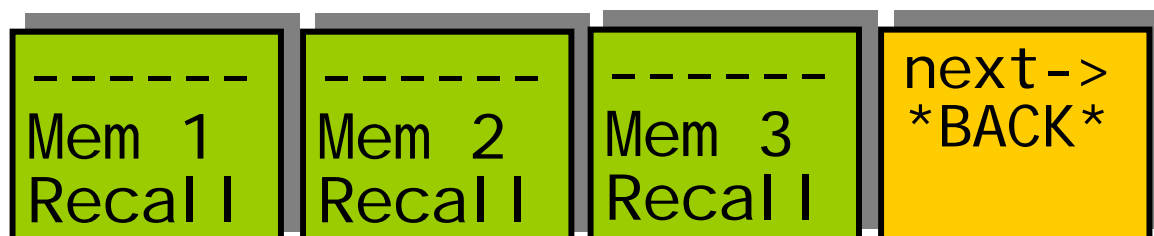

Menu Num.	Heading	Automation	Function
20	MEM1	1=Recall (Variable 1)	Pressing this will recall Memory number 1. User Names can be programmed in to the memories using a keyboard. See "geNETics User guide", section "Giving product Memories names"
21	MEM2	1=Recall (Variable 1)	Pressing this will recall Memory number 2.
22	MEM3	1=Recall (Variable 1)	Pressing this will recall Memory number 3.
23	BACK	none	Got to the Main Preset menus (4-7)

Menus 24-27: Memory Controls

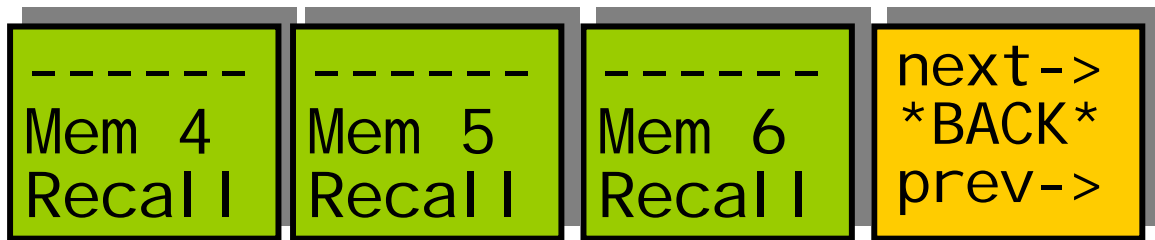

Menu Num.	Heading	Automation	Function
24	MEM4	1=Recall (Variable 1)	Pressing this will recall Memory number 4.
25	MEM5	1=Recall (Variable 1)	Pressing this will recall Memory number 5.
26	MEM6	1=Recall (Variable 1)	Pressing this will recall Memory number 6.
27	BACK	none	Go to the main Preset menus (4-7)

Menu 28-31: Memory Controls

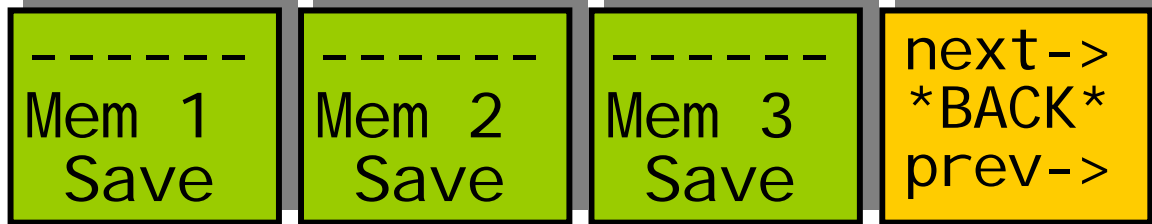

Menu Num.	Heading	Automation	Function
28	Save Mem. #1	1= Save	Pressing this will Save Memory number 1.
29	Save Mem. #	1= Save	Pressing this will Save Memory number 2.
30	Save Mem. #3	1= Save	Pressing this will Save Memory number 3.
31	BACK	none	Go to the main Preset menus (4-7)

Menu 32-35: Memory Controls

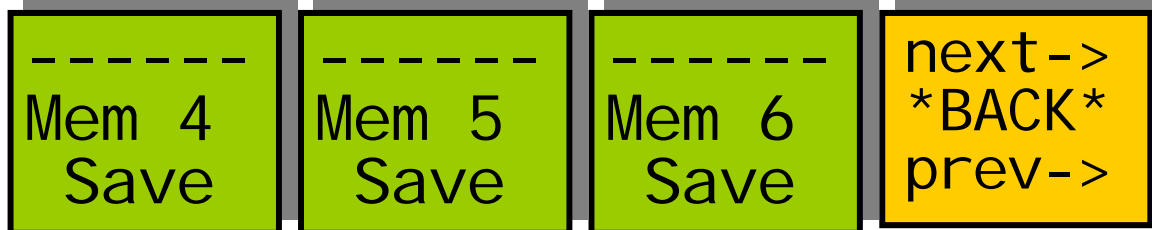

Menu Num.	Heading	Automation	Function
32	Save Mem. #5	1= Save	Pressing this will Save Memory number 4.
33	Save Mem. #6	1= Save	Pressing this will Save Memory number 5.
34	Save Mem. #7	1= Save	Pressing this will Save Memory number 6.
35	BACK	none	Go to the main Preset menus (4-7)

Menu 36-39: RGB/YUV Setup Menus

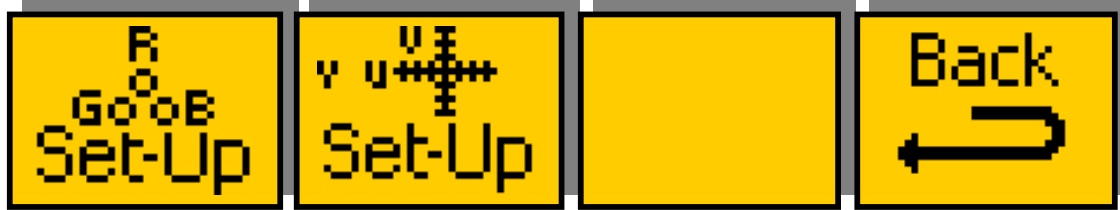

Menu Num.	Heading	Automation	Function
36	RGB Setup	none	Go to the RGB Setup menus (40-43)
37	YUV Setup	none	Go to the YUV Setup menus (52-55)
38	Blank	none	
39	BACK	none	Go to the Setup menus (6-8)

Menu 40-43: RGB Clip and Knee Menus

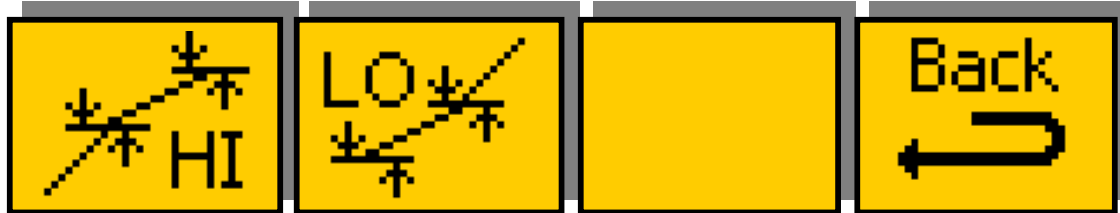

Menu Num.	Heading	Automation	Function
40	Hi	none	Go to the RGB Hi Clip and Hi Knee Clipping menus (44-47)
41	Lo	none	Go to the RGB Lo Clip and Lo Knee Clipping menus (48-51)
42		none	Blank
43	BACK	none	Go to the RGB/YUV menus (36-39)

Menus 44-47: RGB High Clip and Knee settings

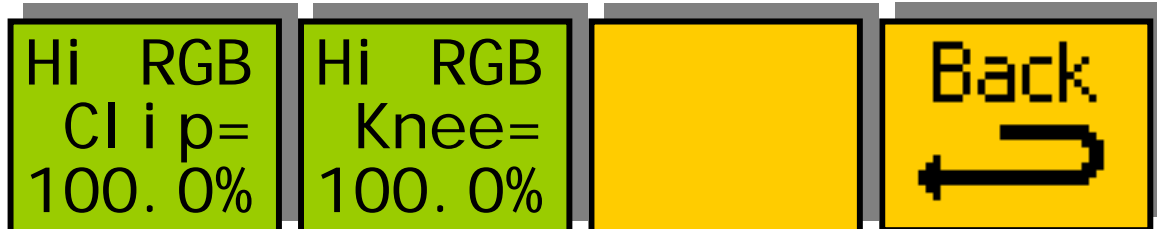

Menu Num.	Heading	Automation	Function
44	High Clip	51% →	This indicates the High Clip point for

	Level	109% [512→1023]	the RGB Clipping. This is normally set to 100% for clipping at 0.7V in the analogue domain.
45	High Knee Level	51% → 109% [512→1023]	This indicates the High Knee point for the RGB Clipping. This can be set to give a “soft clip” from this knee point to the hard clip point.
46		none	Blank
47	BACK	none	Go to the RGB Clip and Knee menus (40-43)

Menu 48-51: RGB Low Clip and Knee Settings

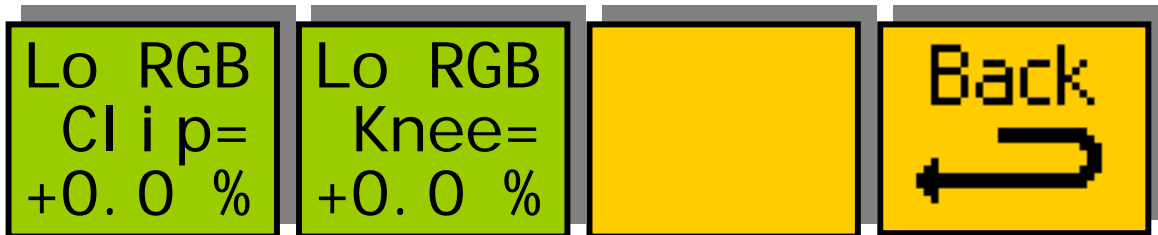

Menu Num.	Heading	Automation	Function
48	Low Clip Level	-7% → 50% [1→511]	This indicates the Low Clip point for the RGB Clipping. This is normally set to 0% for clipping at 0V in the analogue domain.
49	Low Knee Level	-7% → 50% [1→511]	This indicates the Low Knee point for the RGB Clipping. This can be set to give a “soft clip” from this knee point to the Low clip point.
50		none	Blank
51	BACK	none	Go to the RGB Clip and Knee menus (40-43)

Menu 52-55: YUV Clips



Menu Num.	Heading	Automation	Function
52	Y Clips	none	Go to the Y Clip and Knee menus (56-

			59)
53	UV Clips	none	Go to the UV Clip and Knee menus (68-71)
54		none	Blank
55	BACK	none	Go to the RGB/YUV menus (36-39)

Menu 56-59: YUV Y Clip and Knee Menus

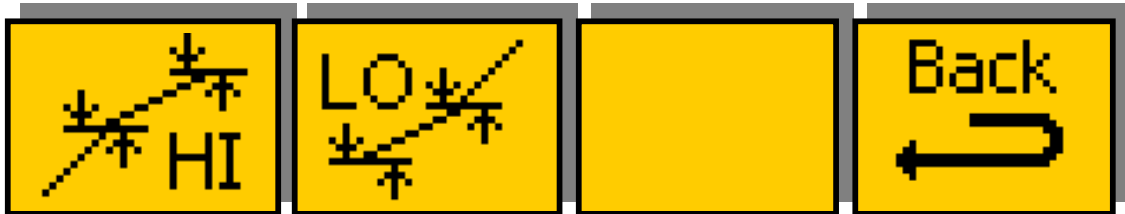

Menu Num.	Heading	Automation	Function
56	Hi	none	Go to the YUV Y Hi Clip and Hi Knee Clipping menus (60-63)
57	Lo	none	Go to the YUV Y Lo Clip and Lo Knee Clipping menus (64-67)
58		none	Blank
59	BACK	none	Go to the YUV menus (52-55)

Menus 60-63: YUV Y High Clip and Knee settings

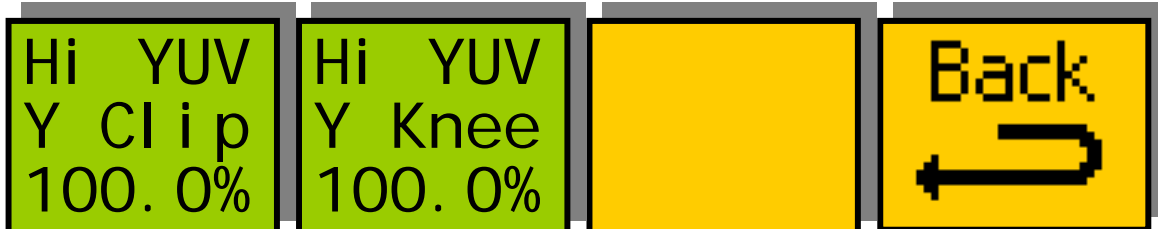

Menu Num.	Heading	Automation	Function
60	High Clip Level	51% → 109% [512→1023]	This indicates the High Clip point for the YUV Y Clipping. This is normally set to 100% for clipping at 0.7V in the analogue domain.
61	High Knee Level	51% → 109% [512→1023]	This indicates the High Knee point for the YUV Y Clipping. This can be set to give a "soft clip" from this knee point to the hard clip point.
62		none	Blank
63	BACK	none	Go to the YUV Y Clip and Knee menus (56-59)

Menu 64-67: YUV Y Low Clip and Knee Settings

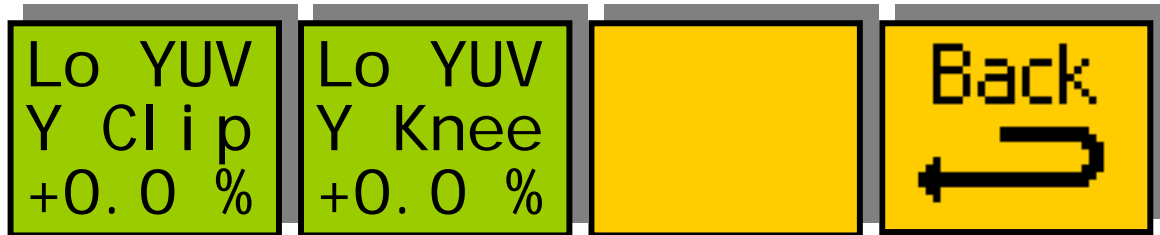

Menu Num.	Heading	Automation	Function
64	Low Clip Level	-7% → 50% [1→511]	This indicates the Low Clip point for the YUV Y Clipping. This is normally set to 0% for clipping at 0V in the analogue domain.
65	Low Knee Level	-7% → 50% [1→511]	This indicates the Low Knee point for the YUV Y Clipping. This can be set to give a “soft clip” from this knee point to the Low clip point.
66		none	Blank
67	BACK	none	Go to the YUV Y Clip and Knee menus (56-59)

Menu 68-71: YUV UV Clip and Knee Menus

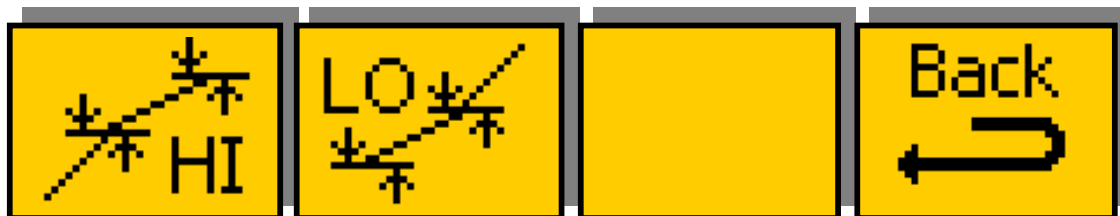

Menu Num.	Heading	Automation	Function
68	Hi	none	Go to the YUV UV Hi Clip and Hi Knee Clipping menus (72-75)
69	Lo	none	Go to the YUV UV Lo Clip and Lo Knee Clipping menus (76-79)
70		none	Blank
71	BACK	none	Go to the YUV menus (52-55)

Menus 72-75: YUV UV High Clip and Knee settings

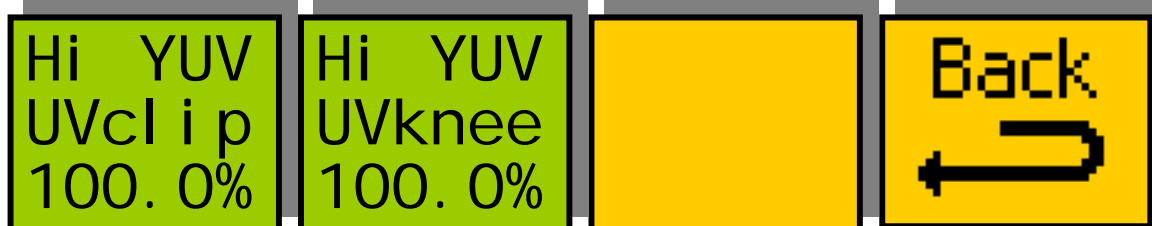

Menu Num.	Heading	Automation	Function
72	High Clip Level	51% → 109% [512→1023]	This indicates the High Clip point for the YUV UV Clipping. This is normally set to 100% for clipping at 0.7V in the analogue domain.
73	High Knee Level	51% → 109% [512→1023]	This indicates the High Knee point for the YUV UV Clipping. This can be set to give a “soft clip” from this knee point to the hard clip point.
74		none	Blank
75	BACK	none	Go to the RGB Clip and Knee menus (68-71)

Menu 76-79: YUV UV Low Clip and Knee Settings

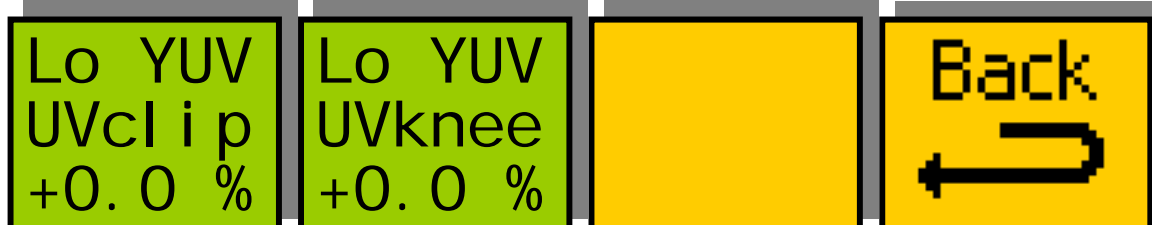

Menu Num.	Heading	Automation	Function
76	Low Clip Level	-7% → 50% [1→511]	This indicates the Low Clip point for the YUV UV Clipping. This is normally set to 0% for clipping at 0V in the analogue domain.
77	Low Knee Level	-7% → 50% [1→511]	This indicates the Low Knee point for the YUV UV Clipping. This can be set to give a “soft clip” from this knee point to the Low clip point.
78		none	Blank
79	BACK	none	Go to the YUV UV Clip and Knee menus (68-71)

Menu 80-83: Composite Clip and Knee Menus (NTSC)

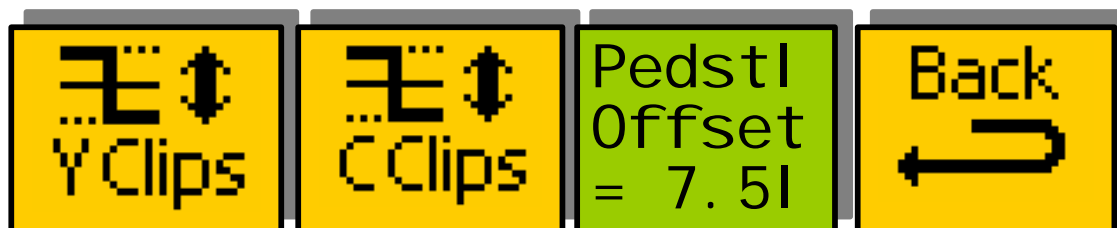

Menu Num.	Heading	Automation	Function
80	Y Clips	none	Go to the Composite Luma Hi/Lo Clip and Hi/Lo Knee Clipping menus (84-87)
81	C Clips	none	Go to the Composite Chroma Hi/Lo Clip and Hi/Lo Knee Clipping menus (96-99)
82	Pedestal	0.0I 7.5I [0:1]	Pedestal IRE setting. This can be set to 0.0 or 7.5 IRE.
83	BACK	none	Go to the Setup menus (8-11)

Menu 84-85: Composite Luma Clip and Knee Menus (NTSC)

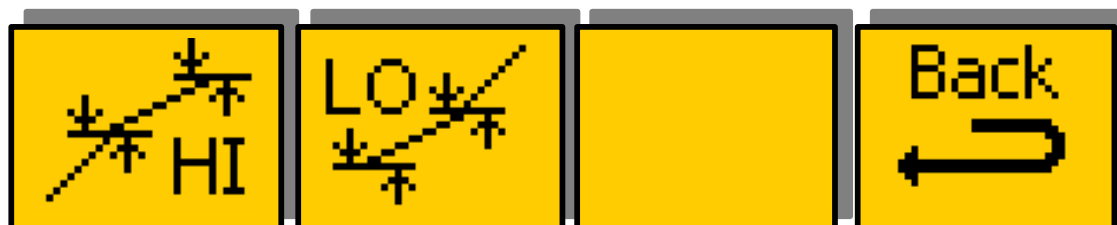

Menu Num.	Heading	Automation	Function
84	Hi	none	Go to the Composite Luma Hi Clip and Hi Knee Clipping menus (88-91)
85	Lo	none	Go to the Composite Luma Lo Clip and Lo Knee Clipping menus (92-95)
86	Blank		
87	BACK	none	Go to the Setup menus (80-83)

Menus 88-91: Composite Luma High Clip and Knee settings (NTSC)



Menu Num.	Heading	Automation	Function
88	High Clip Level	[8-511]	This indicates the High Clip point for the Composite Luma Clipping.
89	High Knee Level	[8-511]	This indicates the High Knee point for the Composite Luma Clipping. This can be set to give a “soft clip” from this knee point to the hard clip point.
90	Blank		
91	BACK	none	Go to the Composite Clip and Knee menus (84-87)

Menu 92-95: Composite Luma Low Clip and Knee Settings (NTSC)



Menu Num.	Heading	Automation	Function
92	Low Clip Level	[8→511]	This indicates the Low Clip point for the Composite Luma Clipping.
93	Low Knee Level	[8→511]	This indicates the Low Knee point for the Composite Luma Clipping. This can be set to give a “soft clip” from this knee point to the hard clip point.
94	Blank		
95	BACK	none	Go to the Composite Clip and Knee menus (84-87)

Menu 96-99: Composite Chroma Clip and Knee Menus (NTSC)



Menu Num.	Heading	Automation	Function
96	Hi	none	Go to the Composite Chroma Hi Clip and Hi Knee Clipping menus (100-103)
97	Lo	none	Go to the Composite Luma Lo Clip and Lo Knee Clipping menus (104-107)
98	Blank		
99	BACK	none	Go to the Setup menus (80-83)

Menus 100-103: Composite Chroma High Clip and Knee settings (NTSC)

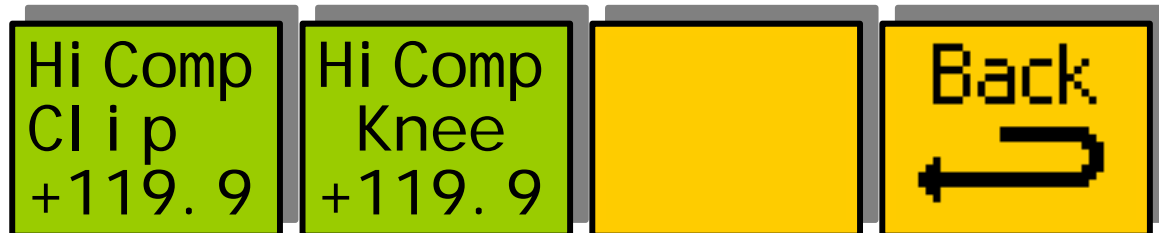

Menu Num.	Heading	Automation	Function
100	High Clip Level	[8-511]	This indicates the High Clip point for the Composite Chroma Clipping.
101	High Knee Level	[8-511]	This indicates the High Knee point for the Composite Chroma Clipping. This can be set to give a "soft clip" from this knee point to the hard clip point.
102	Blank		
103	BACK	none	Go to the Composite Clip and Knee menus (96-99)

Menu 104-107: Composite Chroma Low Clip and Knee Settings (NTSC)

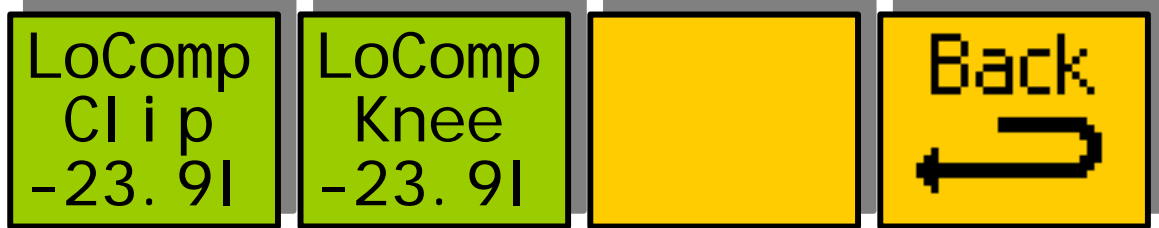

Menu Num.	Heading	Automation	Function
104	Low Clip Level	[8→511]	This indicates the Low Clip point for the Composite Chroma Clipping.
105	Low Knee Level	[8→511]	This indicates the Low Knee point for the Composite Chroma Clipping. This can be set to give a “soft clip” from this knee point to the hard clip point.
106	Blank		
107	BACK	none	Go to the Composite Clip and Knee menus (96-99)

Menu 80-83: Composite Clip and Knee Menus (PAL)

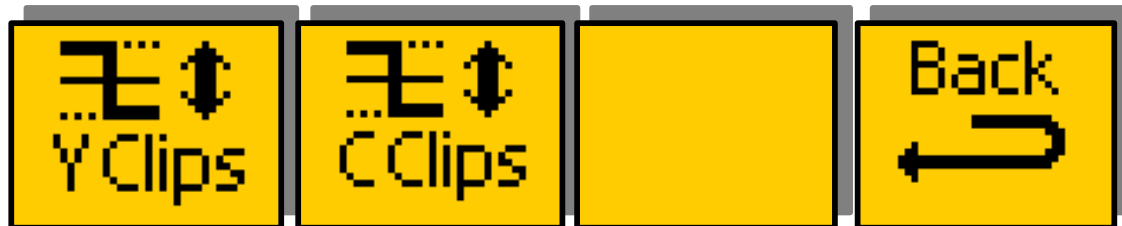

Menu Num.	Heading	Automation	Function
80	Y Clips	none	Go to the Composite Chroma Hi/Lo Clip and Hi/Lo Knee Clipping menus (84-87)
81	C Clips	none	Go to the Composite Chroma Hi/Lo Clip and Hi/Lo Knee Clipping menus (96-99)
82	Blank		
83	BACK	none	Go to the Setup menus (8-11)

Menu 84-87: Composite Luma Clip and Knee Menus (PAL)

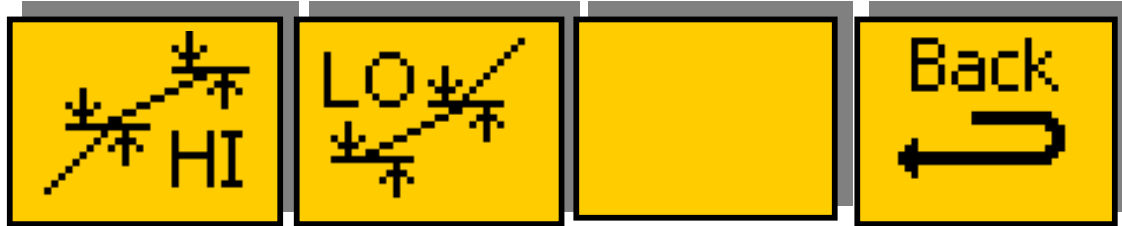

Menu Num.	Heading	Automation	Function
84	Hi	none	Go to the Composite Luma Hi Clip and Hi Knee Clipping menus (88-91)
85	Lo	none	Go to the Composite Luma Lo Clip and Lo Knee Clipping menus (92-95)
86		none	Blank
87	BACK	none	Go to the Setup menus (80-83)

Menus 88-91: Composite Luma High Clip and Knee settings (PAL)



Menu Num.	Heading	Automation	Function
88	High Clip Level	[8-511]	This indicates the High Clip point for the Composite Luma Clipping.
89	High Knee Level	[8-511]	This indicates the High Knee point for the Composite Luma Clipping. This can be set to give a “soft clip” from this knee point to the hard clip point.
90	Blank		
91	BACK	none	Go to the Composite Clip and Knee menus (84-87)

Menu 92-95: Composite Luma Low Clip and Knee Settings (PAL)



Menu Num.	Heading	Automation	Function
92	Low Clip Level	[8→511]	This indicates the Low Clip point for the Composite Luma Clipping.
93	Low Knee Level	[8→511]	This indicates the Low Knee point for the Composite Luma Clipping. This can be set to give a “soft clip” from this knee point to the Low clip point.
94	Blank		
95	BACK	none	Go to the Composite Clip and Knee menus (80-83)

Menu 96-99: Composite Chroma Clip and Knee Menus (PAL)

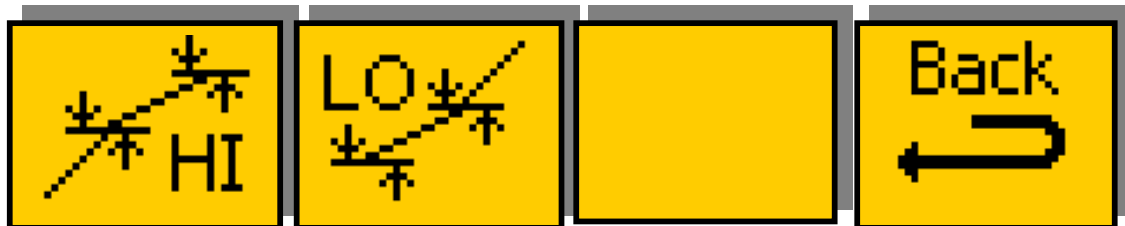

Menu Num.	Heading	Automation	Function
96	Hi	none	Go to the Composite Chroma Hi Clip and Hi Knee Clipping menus (100-103)
97	Lo	none	Go to the Composite Chroma Lo Clip and Lo Knee Clipping menus (104-107)
98		none	Blank
99	BACK	none	Go to the Setup menus (80-83)

Menus 100-103: Composite Chroma High Clip and Knee settings (PAL)

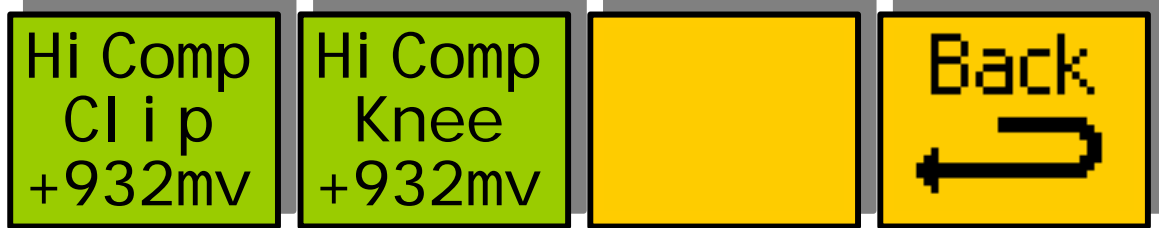

Menu Num.	Heading	Automation	Function
100	High Clip Level	[8-511]	This indicates the High Clip point for the Composite Chroma Clipping.
101	High Knee Level	[8-511]	This indicates the High Knee point for the Composite Chroma Clipping. This can be set to give a “soft clip” from this knee point to the hard clip point.
102	Blank		
103	BACK	none	Go to the Composite Clip and Knee menus (96-99)

Menu 104-107: Composite Chroma Low Clip and Knee Settings (PAL)

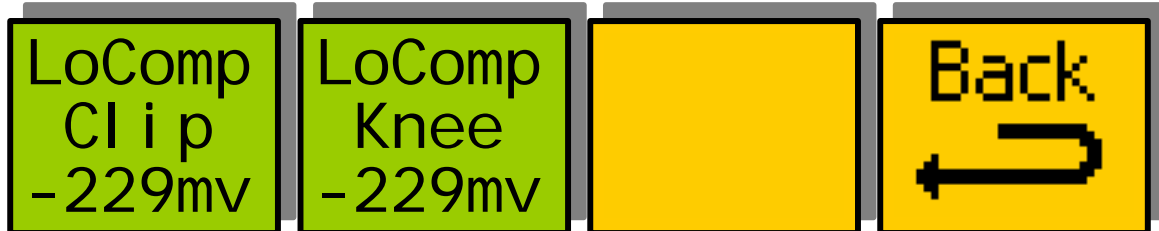

Menu Num.	Heading	Automation	Function
104	Low Clip Level	[8→511]	This indicates the Low Clip point for the Composite Luma Clipping.
105	Low Knee Level	[8→511]	This indicates the Low Knee point for the Composite Luma Clipping. This can be set to give a “soft clip” from this knee point to the Low clip point.
106	Blank		
107	BACK	none	Go to the Composite Clip and Knee menus (96-99)

Menu 108-111: UTILITY MENUS - 1

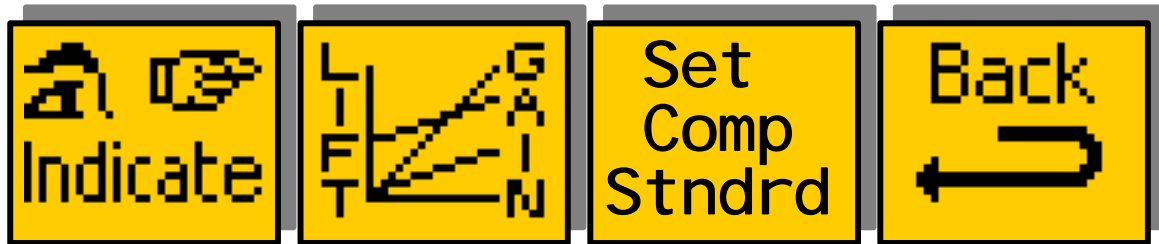

Menu Num.	Heading	Automation	Function
108	LIFT/GAIN	none	Go to the Lift/Gain menus (80-83)
109	INDICATE	none	Go to the Composite Clip and Knee menus (132-135)
110	SET COMP STNDRD	none	Go to the Composite Standard menus (128-131)
111	BACK	none	Go to the Setup menus (8-11)

Menu 112-115: UTILITY MENUS - 2



Menu Num.	Heading	Automation	Function
112	LOG	none	Go to the Log menu (128-131)
113	POM	none	Go to the Power on Memory and Reset (144-147)
114	TIME CODES	none	Go to the Time Code Menus (116-119)
115	BACK	none	Go to the Setup menus (8-11)

Menu 116-119: TIME CODE MENUS

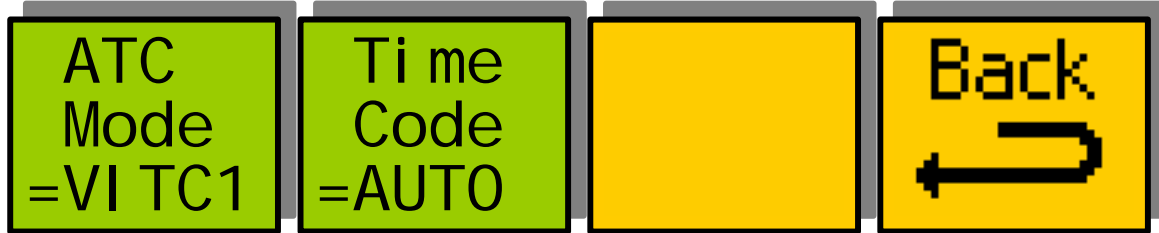

Menu Num.	Heading	Automation	Function
116	ATC Mode	LTC VITC1 VITC2 [0→2]	This selects the time code packet type for ATC time codes.
117	Time Code	ATC LTC AUTO [0→2]	This selects ATC or LTC time codes. In AUTO mode the type of time code is selected automatically based on the time code received.
118	Blank		
119	BACK	none	Go to the Composite Clip and Knee menus (112-115)

Menus 120-123: Out of Gamut Colour

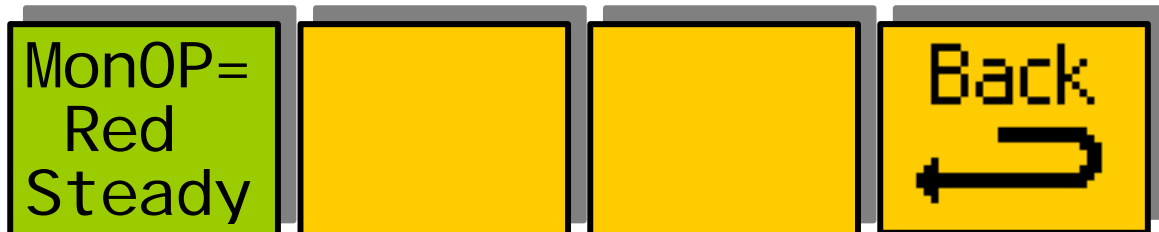

Menu Num.	Heading	Automation	Function
120	MonOP	RedSteady GreenSteady BlueSteady WhiteSteady RedFlash GreenFlash BlueFlash WhiteFlash RawOut LegalOut [0→9]	This is the colour used to indicate the areas of the picture currently being processed by the legaliser.
121	Blank	none	
122	Blank	none	
123	BACK	none	Go to the Utility - 1 menus (108-111)

Menus 124-127: Log mode menus

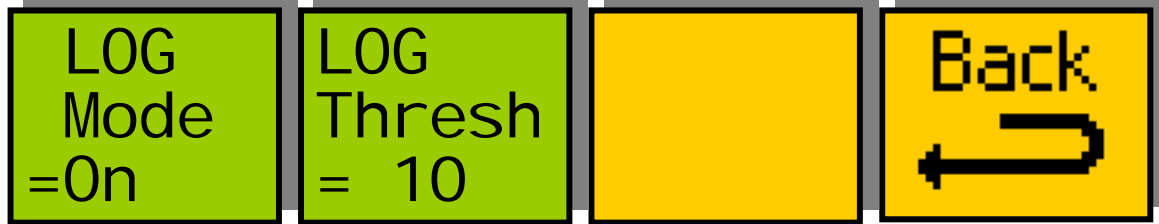

Menu Num.	Heading	Automation	Function
124	Log Mode	Off On [0→1]	This will switch on and off the Error Logging output on the RS232 port. This output can be used in conjunction with the Eyeheight TimeCode software to display the errors and timecodes so that problem sections can easily be located
125	Log Threshold	[0→1023]	Specifies the absolute magnitude of allowable over/undershoot before the pixel is logged as severe in the PC logging application.
126		none	Blank
127	BACK	none	Go To the Utils menus (112-115)

Menus 128-131: COMPOSITE STANDARD MENUS

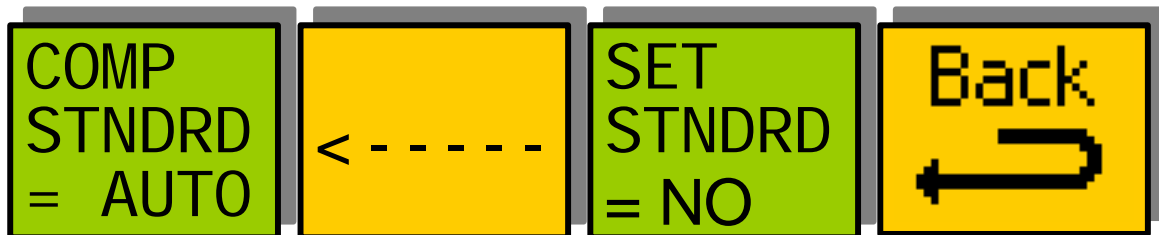

Menu Num.	Heading	Automation	Function
128	COMPOSITE STANDARD	PAL NTSC AUTO [0→2]	This SELECTS the mode for all the menu settings. Selecting "YES" in the SET STANDARD menu will SET the selected mode. In AUTO mode the selected settings are: 1080 @ 24Hz = Stays in last mode 1080 @ 30Hz = NTSC 1080 @ 25Hz = PAL

			720p @ 60Hz = NTSC 720p @ 50Hz = PAL 720p @ 30Hz = NTSC 720p @ 25Hz = PAL 720p @ 24Hz = Stays in last mode
129		none	Blank
130	SET STANDARD	NO YES [0→1]	Selecting "YES" will set all menus to the mode selected in the COMPOSITE STANDARD menu.
131	BACK	none	Go To the Utils menus (108-111)

Menu 132-135): LIFT/GAIN MENUS

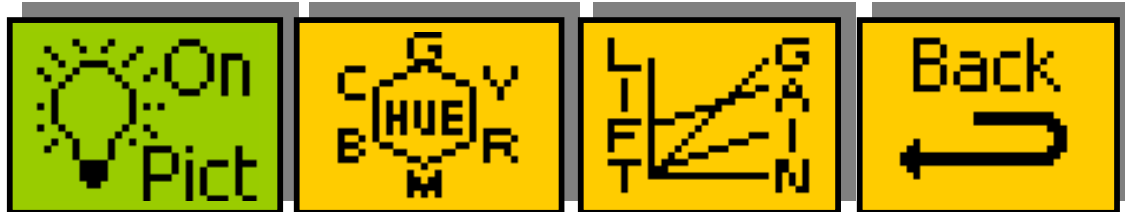

Menu Num.	Heading	Automation	Function
132	Lift, Gain, Hue and Black Control	On Off [0→1]	Active=Proc amp is processing, gain, hue and black controls are active Bypass= Unity Gain and no black offset.
133	HUE	none	Go To the Hue menus (136-139)
134	LIFT/GAIN	none	Go To the Luma, Chroma and Black menus (140-143)
135	BACK	none	Go to the Utility Menus - 1 (108-111)

Menus 136-139: Hue Control

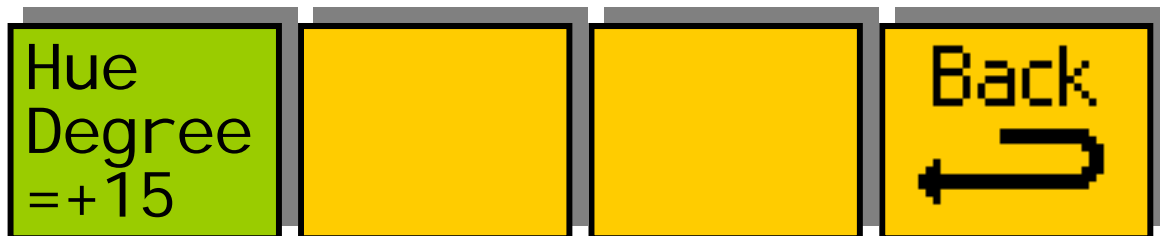

Menu Num.	Heading	Automation	Function
136	Hue	-180 to +180 degrees [-511 → +512]	Hue Rotation value, in degrees.
137		none	Blank
138		none	Blank
139	BACK	none	Go to the Lift/Gain menus (132-135)

Menus 140-143: Processing amplifier status.

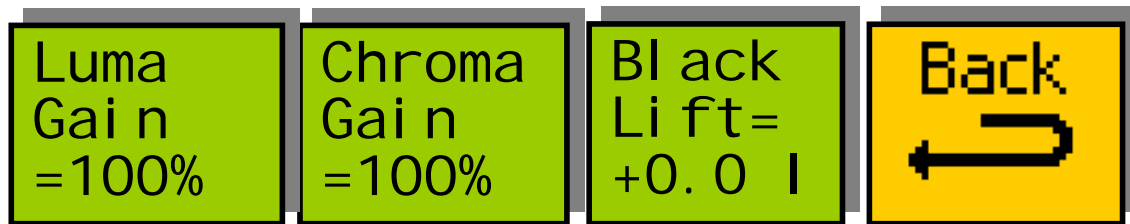

Menu Num.	Heading	Automation	Function
140	Luma Gain	0→200% [0→511]	Luminance Gain Adjustment
141	Chroma Gain	0→200% [0→511]	Chrominance Gain Adjustment
142	Black Level	+/- 20% Range [-255→255]	Black level adjustment
143	BACK	none	Go to the Lift/Gain menus (132-135)

Menu 144-147: Power-on & Reset Controls



Menu Num.	Heading	Automation	Function
144	Set As Pow On Memory	1=save	Pressing this will save the current set up as the power on default.
145	Recall Pow On Memory	1=Recall	Pressing this will recall the power on default settings.

146	TOTAL RESET	1=Reset	Pressing this will reset the system.
147	BACK	none	Go to the Utility Menus - 2 (112-115)

5 PC Logging Application

5.1.1 Installation

The latest version of the logging application can be downloaded from http://www.eyeheight.com/software_top.htm. The software requires the .NET Framework v1.1 to be installed on the PC to be used for logging. The .NET Framework can be downloaded free of charge from <http://www.microsoft.com>.

Extract all files in the LESDC_logger.zip file to a directory of your choice. Run the logger.exe file to start the logger.

5.1.2 Setting Up for Logging

For successful logging the unit needs to be set to generate the logging output by setting the "Log Mode" menu to on. The unit then needs to be connected to a spare COM port on the PC (make a note of the com port number as it will be required when configuring the logging software) using a standard serial cable. Finally the com port needs to be configured in the logging software via the Comms menu.

5.1.3 Understanding the Application

The application provides a graphical log of the percentage of pixels in the incoming video which are considered to be illegal and the GUI can be seen in Figure 10. The application also provides a visual indication of illegal(green) and severely illegal(red) pixels where a pixel is considered to be severely illegal if it is more illegal than the gamut threshold. This enables the operator to isolate the dangerously illegal cases from those caused by minor variations between legaliser designs.

To start logging set up the COM port in the comms menu and then click start. The logging operation can be suspended by hitting the stop button. Where timecode is available to the unit via VITC the application will log data against the timecode. If the timecode stops the log will also stop. If no timecode is present the application will log continually.

The received section gives details of the last log entry received whilst clicking on the graph window brings up the cursor and populates the cursor section with the log entry relating the selected bar. The zoom control allows viewing of a larger area of the log data.

Logs can be saved and opened at a later date using the file menu.

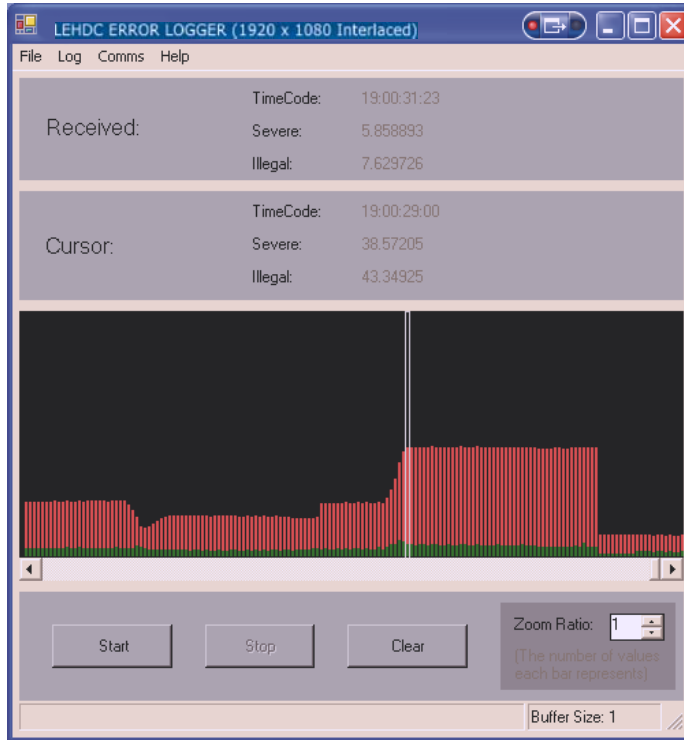

Figure 10 - Logging Application GUI